

Separator Metering System

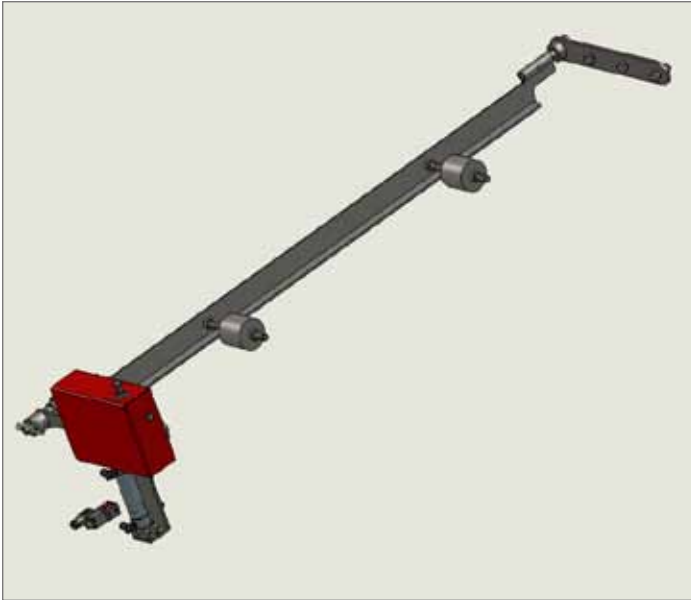

Application

Foundry, Wire Rod, Wire Mesh Machines - Especially effective with differing flow rates

Project Scope

Install an automatic separator flow control system that ensures full flow across the entire width of the separator to improve separator efficiency.

Solution

Metcast "SMS - Separator Metering System"

Results

Abrasive Flow is now regulated across the entire separator air wash. By using an air-operated gate arrangement and a electronic sensor, the separator only is engaged when the abrasive flow is across the entire width. This increases separator efficiency, improves wheel parts life, shot consumption and cleanliness of the parts.

The team at **METCAST SERVICE TECH RESOURCES** looks forward to servicing all of your shotblast requirements.

TECHNOLOGY. SERVICE. SOLUTIONS.